

SECC. A-A

SECC.: B-B

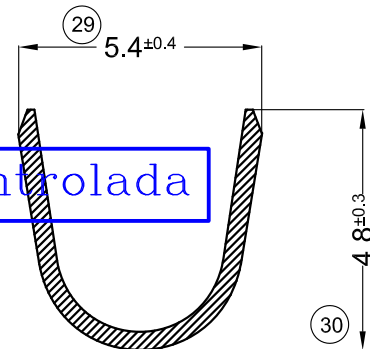
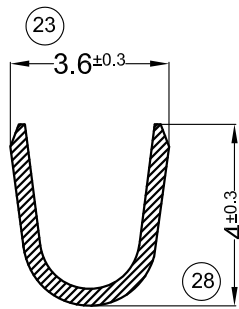

Copia no Controlada

SECC: C-C

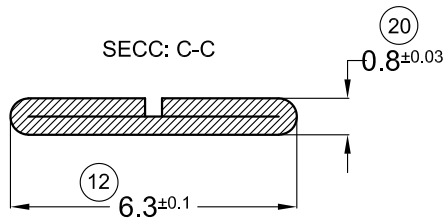

ESCALA: 6:1

ESCALA: 5:1

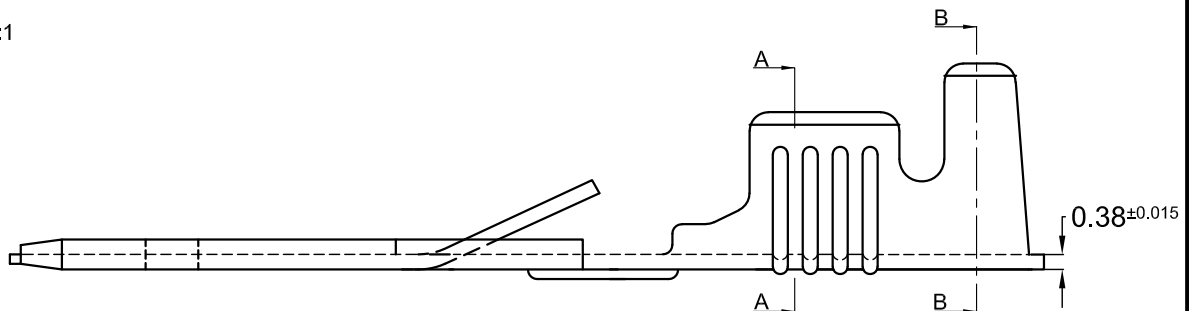

Plano sujeto a modificaciones sin previo aviso

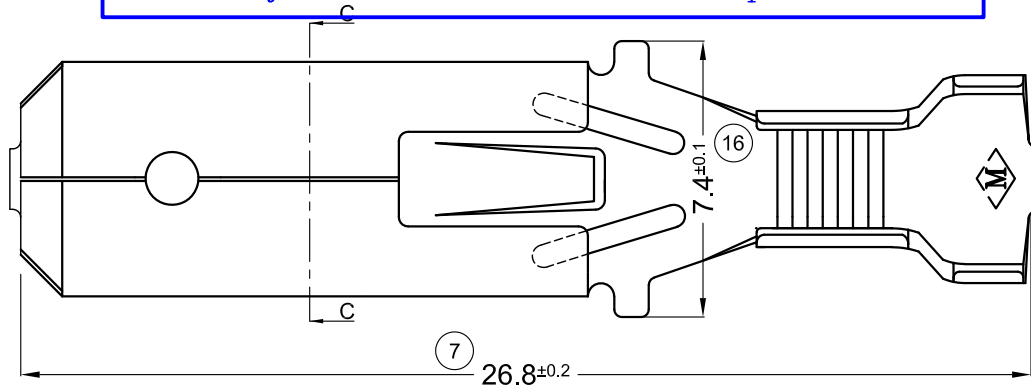

Para presentación sueltos: Codigo sin "C" final

CÓDIGO EN BANDA	MATERIAL	TERMINACIÓN	PIEZAS POR CARRETEL	CANTIDAD SUELTOS
1.02.0845C	LATÓN CuZn 30	NATURAL	5.000	2.000
1.02.0846C	LATÓN CuZn 30	ESTAÑADO	5.000	2.000

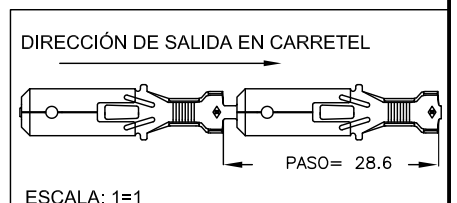

N°	REVISIÓN/FECHA
00	1ª EDICIÓN 26/01/2013
01	CAMBIO FORMATO DE HOJA- 03/12/2021

REVISADO: D.F. DACAL 26/01/2013
 DIBUJADO: F.DACAL 12/01/2013

RANGO CONDUCTOR	METALGRAB S.R.L.
mm ² (AWG) 1-2.5 (18-14)	
Ø AISLANTE mm 2.4-4.1 m/m	TERMINAL: MACHO 6.3 PARA CONECTOR UNIPOLAR PLANO CLIENTE N°: 0845